EPREX[®]

epoetin alfa (r-HuEPO CHO)

DATA SHEET

Use in Cancer

In some studies, use of Erythropoiesis Stimulating Agents (ESAs) to treat anaemia in patients with cancer has been associated with increased mortality. ESAs should only be used to treat anaemia that has developed as a result of concomitantly administered chemotherapy, and only when blood transfusion is not considered appropriate. Haemoglobin levels should not exceed 120g/L (see section 4.4 SPECIAL WARNINGS AND PRECAUTIONS FOR USE).

1. PRODUCT NAME

EPREX 1,000 IU/0.5 mL solution for injection in pre-filled syringe.

EPREX 2,000 IU/0.5 mL solution for injection in pre-filled syringe.

EPREX 3,000 IU/0.3 mL solution for injection in pre-filled syringe.

EPREX 4,000 IU/0.4 mL solution for injection in pre-filled syringe.

EPREX 5,000 IU/0.5 mL solution for injection in pre-filled syringe.

EPREX 6,000 IU/0.6 mL solution for injection in pre-filled syringe.

EPREX 8,000 IU/0.8 mL solution for injection in pre-filled syringe.

EPREX 10,000 IU/1.0 mL solution for injection in pre-filled syringe.

EPREX 20,000 IU/0.5 mL solution for injection in pre-filled syringe

EPREX 30,000 IU/0.75 mL solution for injection in pre-filled syringe

EPREX 40,000 IU/1.0 mL solution for injection in pre-filled syringe.

EPREX[®] is a sterile, preservative-free buffered protein solution of epoetin alfa (rch) in pre-filled syringes. The pre-filled syringes are fitted with the PROTECS[™] needle guard device.

2. QUALITATIVE AND QUANTITATIVE COMPOSITION

Epoetin alfa (r-HuEPO CHO), produced in Chinese Hamster Ovary (CHO) cells by recombinant DNA technology.

A pre-filled syringe of 0.5 mL contains 1,000 IU (8.4 micrograms) of epoetin alfa.

A pre-filled syringe of 0.5 mL contains 2,000 IU (16.8 micrograms) of epoetin alfa.

A pre-filled syringe of 0.3 mL contains 3,000 IU (25.2 micrograms) of epoetin alfa.

A pre-filled syringe of 0.4 mL contains 4,000 IU (33.6 micrograms) of epoetin alfa.

A pre-filled syringe of 0.5 mL contains 5,000 IU (42.0 micrograms) of epoetin alfa.

A pre-filled syringe of 0.6 mL contains 6,000 IU (50.4 micrograms) of epoetin alfa.

A pre-filled syringe of 0.8 mL contains 8,000 IU (67.2 micrograms) of epoetin alfa.

A pre-filled syringe of 1.0 mL contains 10,000 IU (84.0 micrograms) of epoetin alfa.

A pre-filled syringe of 0.5 mL contains 20,000 IU (168.0 micrograms) of epoetin alfa.

A pre-filled syringe of 0.75 mL contains 30,000 IU (252.0 micrograms) of epoetin alfa.

A pre-filled syringe of 1.0 mL contains 40,000 IU (336.0 micrograms) of epoetin alfa.

This medicinal product contains less than 1 mmol sodium (23 mg) per dose, i.e. essentially “sodium free”.

For the full list of excipients, see **section 6.1 List of excipients**.

3. PHARMACEUTICAL FORM

Solution for injection in pre-filled syringe.

Clear, colourless solution.

4. CLINICAL PARTICULARS

4.1 Therapeutic indications

EPREX is indicated for:

- The treatment of severe anaemia of renal origin accompanied by clinical symptoms in patients with renal insufficiency not yet undergoing dialysis.
- Anaemia associated with chronic renal failure in paediatric and adult patients on dialysis.
- Anaemia in patients with non-myeloid malignancies where anaemia is due to the effect of concomitantly administered chemotherapy, and where blood transfusion is not considered appropriate.
- Adult patients with mild-to-moderate anaemia (haemoglobin > 100 to < 130g/L) scheduled for elective surgery with an expected moderate blood loss (2-4 units or 900 to 1800mL) to reduce exposure to allogeneic blood transfusion and to facilitate erythropoietic recovery.
- To augment autologous blood collection and to limit the decline in haemoglobin in anaemic adult patients undergoing major surgery who are not expected to pre-deposit their complete peri-operative blood needs.

4.2 Dose and method of administration

During therapy, haematological parameters should be monitored regularly. Doses must be individualised to ensure that haemoglobin is maintained at an appropriate level for each patient.

As a single anaphylactic reaction was observed in one patient during the course of clinical testing, it is recommended that the first dose be administered under medical supervision.

For treatment of anaemia associated with renal insufficiency or chronic renal failure:

In patients with chronic renal failure, where intravenous access is routinely available (haemodialysis patients) administration of EPREX by the intravenous route is preferable. Where intravenous access is not readily available (patient not yet on dialysis and peritoneal dialysis patients) EPREX may be administered subcutaneously (See **section 4.4 – Pure Red Cell Aplasia**).

In patients maintained on haemodialysis, EPREX should always be administered after completion of dialysis.

Adults:

The recommended starting dose of epoetin alfa (rch) is 50 IU/kg, three times per week, administered as i.v. or s.c. injection over 1-2 minutes. Further dose increments should depend upon the initial response (proposed rate <20 g/L per month). Because of the length of time required for erythropoiesis - several days for erythroid progenitors to mature and be released into the circulation

- a clinically significant increase in haematocrit is usually not observed in less than 2 weeks and may require up to 6 weeks in some patients.

If required, dose increments in steps of 25 IU/kg in intervals of four weeks are recommended. If the rate of haemoglobin rise exceeds 20 g/L per month at 50 IU/kg, three times per week, downward dosage adjustments should be made in the amount administered in each dose and by omitting one of the weekly doses. Similar downward dose adjustments should be made if the Hb level exceeds 120 g/L. Maximum dose should generally not exceed 200 IU/kg three times per week.

When a target haemoglobin concentration of 100-120 g/L (95 to 110g/L in paediatric patients) has been achieved, the total maintenance weekly dose (average 100-300 IU/kg) can be apportioned in two or three injections.

In patients with chronic renal failure, maintenance haemoglobin concentration should not exceed the upper limit of the haemoglobin concentration range.

Available data indicate that patients starting treatment at very low Hb levels (<60g/L) may require higher maintenance dosages than those starting therapy with Hb above 80 g/L; the latter group of patients may need weekly doses as low as 100 IU/kg.

Children:

For paediatric haemodialysis patients:

The treatment is divided into 2 stages:

Correction phase

50 IU/kg/3 times per week by the intravenous route. When a dose adjustment is necessary, this should be done in steps of 25 IU/kg/3 times per week at intervals of at least 4 weeks until the desired goal is achieved.

Maintenance phase:

Appropriate adjustment of the dose should be made in order to maintain the haemoglobin concentration within the desired range between 5.9 to 6.8 mmol/l. Generally, children under 30 kg require higher maintenance doses than children over 30 kg and adults. For example, the following maintenance doses were observed in clinical trials after 6 months of treatment.

Weight (kg)	Median	Dose (IU/Kg given 3 x week) Usual maintenance dose
< 10	100	75 - 150
10 - 30	75	60 - 150
30	33	30 - 100

The clinical data available suggest that those patients whose initial haemoglobin is very low (<6.8 g/dL) may require higher maintenance doses than those whose initial anaemia is less severe (>6.8 g/dL).

Method of Administration

- Parenteral medicine products should be visually inspected for particulate matter and discoloration prior to administration. Product exhibiting particulate matter or discoloration must not be used. Do not shake, shaking may denature the glycoprotein, rendering it inactive.
- Each EPREX syringe is for single use only; only one dose of EPREX should be administered from each syringe. Epoetin alfa in single use syringes contains no preservatives. Do not re-use syringe. Discard unused portion.

- Prepare EPREX for injection from the pre-filled syringe.
- Administer as i.v. or s.c. injection over 1-2 minutes. In patients on dialysis the injection should follow the dialysis procedure. Slow injection over 5 minutes may be beneficial to those who experience flu-like symptoms.
- For subcutaneous dosing a maximum volume of 1mL at any one injection site should not be exceeded. In the case of larger volumes the injection should be divided between more than one site. The injections should be given in the limbs or the anterior abdominal wall.
- Do not dilute or transfer to any other container. Do not administer by intravenous infusion or in conjunction with other medicine solutions.

In situations where the physician determines that a patient or caregiver can safely and effectively administer EPREX subcutaneously, instruction as to the proper dosage and administration should be provided.

Injecting EPREX

If EPREX is injected subcutaneously; the amount injected is not normally more than one millilitre (1 mL) in a single injection.

EPREX is given alone and not mixed with other liquids for injection.

Do not shake EPREX syringes. Prolonged vigorous shaking may damage the product. If the product has been shaken vigorously, don't use it.

How to inject subcutaneously using a pre-filled syringe

The pre-filled syringes are fitted with the PROTECS™ needle guard device to help prevent needle stick injuries after use. The EPREX Consumer Medicine Information includes full instructions for the use and handling of pre-filled syringes.

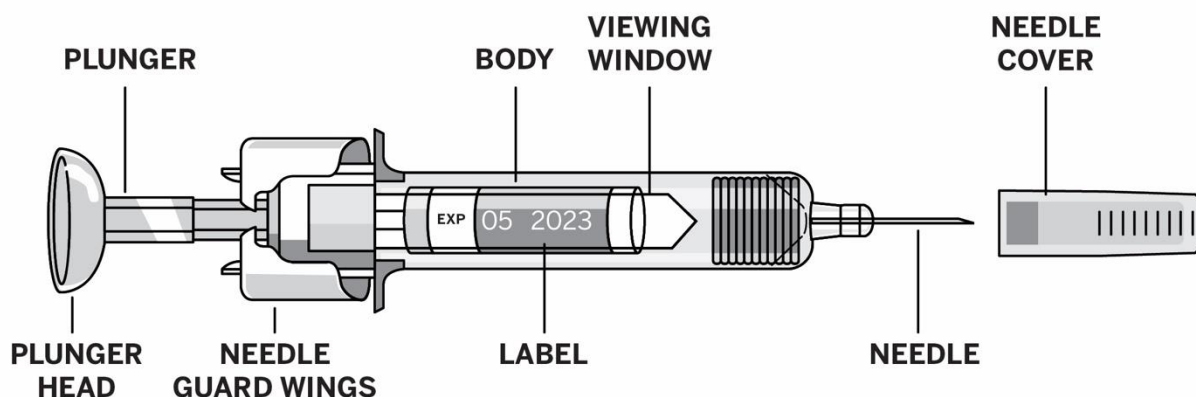

- **Take a syringe out of the refrigerator.** The liquid needs to come to room temperature. This usually takes between 15 to 30 minutes. Do not remove the syringe's needle cover while allowing it to reach room temperature.
- **Check the syringe,** to make sure it is the right dose, has not passed its expiry date, is not damaged, and the liquid is clear and not frozen.
- **Choose an injection site.** Good sites are the top of the thigh and around the abdomen but away from the navel. Vary the site from day to day.
- **Wash your hands. Use an antiseptic swab on the injection site,** to disinfect it.

-
- **Hold the pre-filled syringe by the body of the syringe with the covered needle pointing upward.**
 - **Do not hold by the plunger head, plunger, needle guard wings, or needle cover.**
 - **Do not pull back on the plunger at any time.**
 - **Do not remove the needle cover from the pre-filled syringe until you are ready to inject your EPREX.**
 - **Take the needle cover off the syringe** by holding the body and pulling the needle cover off carefully without twisting it. Don't push the plunger, touch the needle or shake the syringe.
 - Do not touch the needle guard wings to prevent prematurely covering the needle with the needle guard.
 - **Pinch a fold of skin** between your thumb and index finger. Don't squeeze it.
 - **Push the needle in fully.**
 - **Push the plunger with your thumb as far as it will go to inject all of the liquid.** Push it slowly and evenly, keeping the skinfold pinched. The needle guard will not activate unless the entire dose is given. **You may hear a click when the needle guard has been activated.**
 - When the plunger is pushed as far as it will go, take out the needle and let go of the skin.
 - Slowly take your thumb off the plunger. Allow the syringe to move up until the entire needle is covered by the needle guard.
 - **When the needle is pulled out of your skin, there may be a little bleeding at the injection site. This is normal. You can press an antiseptic swab** over the injection site for a few seconds after the injection.
 - **Dispose of your used syringe** in a safe container.
 - Only take one dose of EPREX from each syringe. If any liquid remains in the syringe after an injection, the syringe should be properly disposed of, not reused.

For treatment of anaemia associated with non-myeloid malignancies:

Adults

The haemoglobin concentration range should 100 to 120 g/L in men and women and it should not be exceeded.

Starting dose:

The recommended starting dose of EPREX is 150 IU/kg as a subcutaneous injection three times per week for 4 weeks.

Increase dose:

If the haemoglobin has increased by at least 10 g/L (0.62 mmol/L) or the reticulocyte count has increased $\geq 40,000$ cells/microlitre above baseline after 4 weeks of treatment, the dose should remain at 150 IU/kg. If the haemoglobin increase is < 10 g/L (< 0.62 mmol/L) and the reticulocyte count has increased $< 40,000$ cells/microlitre above baseline, increase the dose to 300 IU/kg.

If after an additional 4 weeks of therapy at 300 IU/kg, the haemoglobin has increased ≥ 10 g/L (≥ 0.62 mmol/L) or the reticulocyte count has increased $\geq 40,000$ cells/microlitre the dose should remain at 300 IU/kg. However, if the haemoglobin has increased < 10 g/L (< 0.62 mmol/L) and the reticulocyte count has increased $< 40,000$ cells/microlitre above baseline, response is unlikely and treatment should be discontinued.

A rate of rise in haemoglobin of greater than 10g/L per 2 week or 20g/L per month, or haemoglobin levels of >120g/L should be avoided. If the haemoglobin is rising by more than 10 g/L per two week or 20g/L per month, or haemoglobin is approaching 120g/L, reduce the Epoetin Alfa dose by about 25-50% depending on the rate of rise of haemoglobin. If the haemoglobin exceeds 120g/L, withhold therapy until it falls below 120g/L and then reinitiate Epoetin Alfa at a dose 25% below the previous dose.

Adult patients scheduled for elective surgery:

The subcutaneous route of administration should be used.

The recommended dose regimen is 600 IU/kg EPREX given weekly for three weeks (Days -21, -14, and -7) prior to surgery and on the day of surgery. In cases where there is a medical need to shorten the lead time before surgery to less than three weeks, 300 IU/kg EPREX should be given daily for 10 consecutive days prior to surgery, on the day of surgery, and for four days immediately thereafter. The administration of EPREX should be stopped as soon as the haemoglobin level reaches 150 g/L in the pre-operative period, even if not all the planned EPREX doses have been given.

Anaemic adult surgery patients in an Autologous Pre-donation Programme (ABD):

The intravenous route should be used. The recommended dose is 300 – 600 IU/kg twice weekly for three weeks, together with at least 200 mg oral elemental iron daily.

4.3 Contraindications

- EPREX is contraindicated in patients with uncontrolled hypertension, known sensitivity to mammalian cell derived products, and/or hypersensitivity to any component of the product. Patients who develop Pure Red Cell Aplasia (PRCA) following treatment with any erythropoietin product should not receive EPREX or any other erythropoietin.
- The use of EPREX in patients scheduled for elective surgery (and who are not participating in an autologous blood pre deposit programme), is contraindicated in patients with severe coronary, peripheral arterial, carotid, or cerebral vascular disease, including patients with recent myocardial infarction or cerebral vascular accident.
- Surgery patients who for any reason cannot receive adequate antithrombotic prophylaxis or treatment.
- All contraindications associated with autologous blood predonation programs should be respected in patients being supplemented with EPREX.

4.4 Special warnings and precautions for use

Cardiovascular and thrombotic events / increased mortality

Cardiovascular and thrombotic events such as myocardial ischaemia and infarction, cerebrovascular haemorrhage and infarction, transient ischaemic attacks, deep venous thrombosis, arterial thrombosis, pulmonary emboli, retinal thrombosis and haemodialysis graft occlusion have been reported in patients receiving erythropoiesis stimulating agents such as EPREX.

An increased incidence of thrombotic vascular events (TVEs) has been observed in patients receiving ESAs (see **section 4.8**) These include venous and arterial thromboses and embolism (including some with fatal outcomes), such as deep venous thrombosis, pulmonary emboli, retinal thrombosis, and myocardial infarction. Additionally, cerebrovascular accidents (including cerebral infarction, cerebral haemorrhage and transient ischaemic attacks) have been reported.

The reported risk of TVEs should be carefully weighed against the benefits to be derived from treatment with Epoetin alfa particularly in patients with pre-existing risk factors.

EPREX and other erythropoiesis-stimulating agents increased the risk for death and for serious cardiovascular events in controlled clinical trials when administered to target a haemoglobin of greater than 120 g/L. There was an increased risk of serious arterial and venous thromboembolic events, including myocardial infarction, stroke, congestive heart failure and haemodialysis graft occlusion. A rate of haemoglobin rise of greater than 10 g/L over 2 weeks may also contribute to these risks.

In all patients, haemoglobin concentrations should be closely monitored due to a potential increased risk of thromboembolic events and fatal outcomes when patients are treated at haemoglobin concentrations above the range for the indication of use.

Growth factor potential / increased tumour progression

Epoetin alfa is a growth factor that primarily stimulates red blood cell production. Like all growth factors there is a theoretical concern that epoetin alfa could act as a growth factor for any tumour type, particularly myeloid malignancies. Erythropoiesis-stimulating agents (ESAs), when administered to target a haemoglobin of greater than 120 g/L, shortened the time to tumour progression in patients with advanced head and neck cancer receiving radiation therapy. ESAs also shortened survival in patients with metastatic breast cancer receiving chemotherapy when administered to a target haemoglobin greater than 120 g/L.

Use in cancer patients

Cancer patients on EPREX should have haemoglobin levels measured on a regular basis until a stable level is achieved and periodically thereafter.

ESAs are growth factors that primarily stimulate red blood cell production. Erythropoietin receptors may be expressed on the surface of a variety of tumour cells. As with all growth factors, there is a concern that ESAs could stimulate the growth of tumours.

In controlled clinical studies, use of EPREX and other ESAs have shown:

- decreased locoregional control in patients with advanced head and neck cancer receiving radiation therapy when administered to a haemoglobin target of greater than 140 g/L,
- shortened overall survival and increased deaths attributed to disease progression at 4 months in patients with metastatic breast cancer receiving chemotherapy when administered to a haemoglobin target of 120-140 g/L,
- Another ESA (darbepoetin alfa) increased risk of death when administered to target a haemoglobin of 120 g/L in patients with active malignant disease receiving neither chemotherapy nor radiation therapy. ESAs are not indicated for use in this patient population.

In view of the above, the decision to administer recombinant erythropoietin treatment should be based on a benefit-risk assessment with the participation of the individual patient, which should take into account the specific clinical context. Factors to consider in this assessment include: the type of tumour and its stage; the degree of anaemia; life-expectancy; the environment in which the patient is being treated; and patient preference.

Use in chronic renal failure patients

Chronic renal failure patients being treated with Epoetin alfa should have haemoglobin levels measured on a regular basis until a stable level is achieved, and periodically thereafter.

In chronic renal failure patients the rate of increase in haemoglobin should be approximately 10 g/L per month and should not exceed 20 g/L per month to minimise risks of an increase in hypertension. Dose should be reduced when haemoglobin approaches 120 g/L.

In patients with chronic renal failure, maintenance haemoglobin concentration should not exceed the upper limit of the target haemoglobin concentration range as recommended under Dosage and Administration. Haemoglobin levels targeted to 130 g/L or higher may be associated with a higher risk of cardiovascular events, including death.

Patients with chronic renal failure and insufficient hemoglobin response to ESA therapy may be at even greater risk for cardiovascular events and mortality than other patients.

Shunt thromboses have occurred in haemodialysis patients, especially in those who have a tendency to hypotension or whose arteriovenous fistulae exhibit complications (e.g., stenoses, aneurysms, etc.) Early shunt revision and thrombosis prophylaxis by administration of acetylsalicylic acid, for example, is recommended in these patients.

Hyperkalaemia has been observed in isolated cases, though causality has not been established. Serum electrolytes should be monitored in chronic renal failure patients. If an elevated or rising serum potassium level is detected, then in addition to the appropriate treatment of the hyperkalaemia, consideration should be given to ceasing EPREX administration until the serum potassium level has been corrected.

As a result of an increase in packed cell volume, haemodialysis patients receiving EPREX frequently require an increase in heparin dose during dialysis. If heparinisation is not optimal, occlusion of the dialysis system is possible.

In some female chronic renal failure patients, menses have resumed following EPREX therapy; the possibility of potential pregnancy should be discussed and the need for contraception evaluated.

Hypertension

Patients with uncontrolled hypertension should not be treated with EPREX; blood pressure should be controlled adequately before initiation of therapy. Blood pressure may rise during treatment of anaemia with EPREX. Hypertensive crisis with encephalopathy and seizures, requiring the immediate attention of a physician and intensive medical care, have also occurred during EPREX treatment in patients with previously normal or low blood pressure. Particular attention should be paid to sudden stabbing migraine-like headaches as a possible warning signal (see **section 4.8**). Special care should be taken to closely monitor and control blood pressure in patients treated with EPREX. During EPREX therapy, patients should be advised of the importance of compliance with antihypertensive therapy and dietary restrictions. If blood pressure is difficult to control after initiation of appropriate measures, the dose of EPREX should be reduced or temporarily withheld until haemoglobin begins to decrease (see **section 4.2**).

Pure red cell aplasia

Antibody-mediated pure red cell aplasia (PRCA) (erythroblastopaenia) has been reported after treatment with erythropoietins. Most cases of PRCA associated with EPREX occurred in patients receiving subcutaneous (SC) administration. The SC route should only be used when intravenous (IV) access is not readily available. Cases also have been rarely reported in patients with hepatitis C treated with interferon and ribavirin, when ESAs are used concomitantly. ESAs are not approved in the management of anaemia associated with hepatitis C.

In most of these PRCA patients antibodies to erythropoietins have been reported. In patients developing sudden lack of efficacy typical causes of non-response should be investigated. If no cause is identified, a bone marrow examination should be considered.

If pure red cell aplasia (PRCA) is diagnosed, EPREX must be immediately discontinued and testing for erythropoietin antibodies should be considered. If antibodies to erythropoietin are detected patients should not be switched to another ESA product as anti-erythropoietin antibodies cross-react with other ESAs. Other causes of pure red cell aplasia should be excluded, and appropriate therapy instituted.

Seizures

EPREX should be used with caution in patients with epilepsy, history of seizures, or medical conditions associated with a predisposition to seizure activity such as CNS infections and brain metastases.

Iron supplementation

Other causes of anaemia (iron, folate or Vitamin B₁₂ deficiency, aluminium intoxication, infection or inflammation, blood loss, haemolysis and bone marrow fibrosis of any origin) should be evaluated and treated prior to initiating therapy with EPREX, and when deciding to increase the dose. In most cases, the ferritin values in the serum fall simultaneously with the rise in packed cell volume. In order to ensure optimum response to EPREX, adequate iron stores should be assured and iron supplementation should be administered if necessary:

- For chronic renal failure patients, iron supplementation (elemental iron 200-300 mg/day orally for adults and 100-200 mg/day orally for paediatrics) is recommended if serum ferritin levels are below 100 ng/mL.
- For cancer patients, iron supplementation (elemental iron 200-300 mg/day orally) is recommended if transferrin saturation is below 20%.
- For patients in an autologous predonation programme, iron supplementation (elemental iron 200 mg/day orally) should be administered several weeks prior to initiating the autologous predeposit in order to achieve high iron stores prior to starting EPREX therapy, and throughout the course of EPREX therapy.
- For patients scheduled for major elective orthopaedic surgery, iron supplementation (elemental iron 200mg/day orally) should be administered throughout the course of EPREX therapy. If possible, iron supplementation should be initiated prior to starting EPREX therapy to achieve adequate iron stores.

General

EPREX should be used with caution in those patients with pre-existing hypertension, ischaemic vascular disease, epilepsy, history of seizures, or medical conditions associated with a predisposition to seizure activity such as CNS infections and brain metastases.

The safety and effectiveness of epoetin alfa has not been established in patients with underlying haematologic diseases (e.g. haemolytic anaemia, sickle cell disease, thalassemia, porphyria).

Erythropoiesis-stimulating agents (ESAs) are not necessarily equivalent. Therefore, it should be emphasised that patients should only be switched from one ESA (such as EPREX) to another ESA with the authorisation of the treating physician.

There may be a moderate dose-dependent rise in the platelet count, within the normal range, during treatment with Epoetin alfa. This regresses during the course of continued therapy. In addition, thrombocythaemia above the normal range has been reported. It is recommended that the platelet count should be regularly monitored during the first 8 weeks of therapy.

Very rarely, exacerbation of porphyria has been observed in EPREX-treated patients with chronic renal failure. EPREX has not caused increased urinary excretion of porphyrin metabolites in normal volunteers, even in the presence of a rapid erythropoietic response. Nevertheless, EPREX should be used with caution in patients with known porphyria.

Increased serum uric acid may occur in patients whose haemoglobin is rising more than approximately 20 g/L per month. Consequently, EPREX should be used with caution in patients with a history of gout.

EPREX should also be used with caution in patients with chronic liver failure. The safety and dosage regime of EPREX has not been established in the presence of hepatic dysfunction. Due to decreased metabolism, patients with hepatic dysfunction may have increased erythropoiesis with EPREX.

Blistering and skin exfoliation reactions including erythema multiforme and Stevens-Johnson Syndrome (SJS)/toxic epidermal necrolysis (TEN), have been reported in a small number of patients treated with EPREX. Discontinue EPREX therapy immediately if a severe cutaneous reaction, such as SJS/TEN, is suspected.

The needle cover on the EPREX pre-filled syringe contains dry natural rubber (a derivative of latex), which may cause allergic reactions in individuals sensitive to latex.

Abuse potential

Abuse is the intentional, non-therapeutic use of a drug, even once, for its desirable psychological or physiological effects. Abuse of EPREX may be seen in athletes for the effects on erythropoiesis. Abuse of drugs that increase erythropoiesis, such as EPREX, by healthy persons may lead to life-threatening cardiovascular complications (e.g., stroke, myocardial infarction, or thromboembolism).

Renal dialysis

Correction of anaemia with EPREX does not appear to affect dialysis efficiency. However, an increase in appetite could lead to increased potassium intake and hyperkalaemia in both dialysis and pre-dialysis patients. This and other alterations in serum chemistry should be managed by dietary alterations and modifications of the dialysis prescription, if appropriate.

Serum electrolytes should be monitored in chronic renal failure patients. If an elevated (or rising) serum potassium level is detected consideration should be given to ceasing epoetin alfa treatment until hyperkalaemia has been corrected.

In some pre-clinical toxicological studies in dogs and rats, but not in monkeys, epoetin alfa (rch) therapy was associated with subclinical bone marrow fibrosis. Bone marrow fibrosis is a known complication of chronic renal failure in humans and may be related to secondary hyperparathyroidism or unknown factors. The incidence of bone marrow fibrosis was not increased in a study of dialysis patients who were treated with EPREX for 12-19 months compared with the incidence of bone marrow fibrosis in a matched control group of dialysis patients who had not been treated with EPREX. In a 13-week study, dogs were treated subcutaneously or intravenously with 80, 240, or 520 IU/kg/day. The majority of dogs treated subcutaneously and 50% of dogs treated intravenously developed anaemia with or without bone marrow hypoplasia. The cause of these observations is unknown, however, no cases of paradoxical anaemia have been reported in haematologically normal humans treated with EPREX, making the significance of the findings in dogs unclear.

Use in surgery

Potentially correctable anaemia should be investigated and appropriately treated before considering therapy with EPREX prior to elective surgery.

In patients with a baseline haemoglobin of >130 g/L (8.1 mmol/L), the possibility that EPREX treatment may be associated with an increased risk of postoperative thrombotic vascular events cannot be excluded. Therefore, it should not be used in patients with a baseline haemoglobin >130 g/L (8.1 mmol/L).

All special precautions associated with autologous pre-donation programmes, especially routine volume replacement, should be respected.

Good blood management practices should always be used in the perisurgical setting.

Use in children

Efficacy: Clinical trials of EPREX in children supported the following effects - correction of anaemia; reduction or elimination of transfusion-requirements; improvement of the bleeding tendency in uraemia; increased weight and appetite; and the reduction of cytotoxic antibodies. Possible but not conclusive effects were an improvement in exercise capacity and short-term cardiovascular effects.

Long-term cardiovascular effects, effects on growth rate, improved prospects for renal transplantation, and improved quality of life were unproved.

Safety: Incomplete information is available, particularly on the rate of change of haemoglobin and blood pressure.

Dose: Available data supports a dose of 25 IU/kg three times a week rather than 50 IU/kg three times a week.

4.5 Interactions with other medicines and other forms of interaction

There are no known clinically significant medicine interactions, but the effect of epoetin alfa (rch) may be potentiated by the simultaneous therapeutic administration of a haematinic agent such as ferrous sulfate when a deficiency state exists.

Drugs that decrease erythropoiesis may decrease the response to epoetin alfa (rch).

No evidence exists that indicates that treatment with epoetin alfa (rch) alters the metabolism of other drugs. However, since cyclosporin is bound by RBC's there is potential for a drug interaction. If epoetin alfa (rch) is given concomitantly with cyclosporin, blood levels of cyclosporin should be monitored and the dose of cyclosporin adjusted as the haematocrit rises.

No evidence exists that indicates an interaction between epoetin alfa (rch) and G-CSF or GM-CSF with regard to haematological differentiation or proliferation of tumour biopsy specimens *in vitro*.

In patients with metastatic breast cancer, subcutaneous co-administration of 40,000 IU/mL epoetin alfa with trastuzumab (6 mg/kg) had no effect on the pharmacokinetics of trastuzumab.

4.6 Fertility, pregnancy and lactation

Pregnancy

The drug is classed as Category B3. EPREX should be administered during pregnancy only if clearly needed and if the potential benefit justifies the potential risk to the foetus. It is not known whether Epoetin alfa (rch) crosses the placenta or whether it can cause fetal harm when administered to a pregnant woman. Animal studies have shown no evidence of teratogenic activity in rats or rabbits at Epoetin alfa (rch) dosages up to 55 IU/kg/day administered intravenously. However, intravenous administration of Epoetin alfa (rch) at dose levels of 20-500 IU/kg/day in rats causes decreased fertility, increased pre- and post-implantation loss, decreased fetal weight and retardation of ossification.

In pregnant or lactating surgical patients participating in an autologous blood predonation programme, the use of EPREX is not recommended.

Breastfeeding

EPREX should be administered during lactation only if clearly needed. It is not known whether Epoetin alfa (rch) is excreted in breast milk or whether it can cause harm to the infant when administered to a lactating woman. Intravenous administration of the drug to lactating rats at 500 IU/kg/day causes retardation of growth and development of the offspring.

4.7 Effect on ability to drive and use machines

Due to the increased risk of hypertension during the initial phase of EPREX treatment, patients with chronic renal failure should use caution when performing potentially hazardous activities, such as driving or operating machinery, until the optimal maintenance dose of EPREX has been established.

4.8 Undesirable effects

The most frequent adverse drug reaction during treatment with Epoetin alfa is a dose-dependent increase in blood pressure or aggravation of existing hypertension. Monitoring of the blood pressure should be performed, particularly at the start of therapy. The most frequently occurring adverse drug

reactions observed in clinical trials of EPREX are diarrhoea, nausea, vomiting, pyrexia, and headache. Influenza-like illness may occur especially at the start of treatment.

An increased incidence of thrombotic vascular events (TVEs), has been observed in patients receiving ESAs (See 4.4).

Hypersensitivity reactions, including cases of rash (including urticaria, anaphylactic reaction, and angio-oedema have been reported.

Hypertensive crisis with encephalopathy and seizures, requiring the immediate attention of a physician and intensive medical care, have occurred also during Epoetin alfa treatment in patients with previously normal or low blood pressure. Particular attention should be paid to sudden stabbing migraine-like headaches as a possible warning signal.

Clinical trial experience

Of a total 3559 subjects in 27 randomized, double-blinded, placebo or standard of care controlled studies, the overall safety profile of EPREX was evaluated in 2136 anaemic subjects. Included were 228 Epoetin alfa-treated CRF subjects in 4 chronic renal failure studies (2 studies in predialysis [N=131 exposed CRF subjects not yet on dialysis] and 2 in dialysis [N=97 exposed CRF subjects on dialysis]; 1,404 exposed cancer subjects in 16 studies of anemia due to chemotherapy; 144 exposed subjects in 4 HIV-infection studies; 147 exposed subjects in 2 studies for autologous blood donation; and 213 exposed subjects in 1 study in the perisurgical setting. Adverse drug reactions reported by $\geq 1\%$ of subjects treated with epoetin alfa in these trials are shown in **Table 1**.

Table 1: Summary of Adverse Drug Reactions Reported by ≥1% of Subjects in Clinical Registration Trials with EPREX.

System/Organ Class Adverse Drug Reaction	<u>CRF</u>		<u>Oncology</u>		<u>HIV</u>		<u>ABD</u>		<u>Surgery</u>			
	<u>Predialysis</u>		<u>Dialysis</u>		EPO	Non- ESA	EPO	Placebo	EPO	Non- ESA	EPO	Placebo
	EPO	Placebo	EPO	Placebo								
N=131 n (%)	N=79 n (%)	N=97 n (%)	N=46 n (%)	N=1404 n (%)	N=930 n (%)	N=144 n (%)	N=153 n (%)	N=147 n (%)	N=112 n (%)	N=213 n (%)	N=103 n (%)	
Gastrointestinal disorders												
Nausea	14 (11)	10 (13)	23 (24)	13 (28)	265 (19)	193 (21)	36 (25)	39 (25)	26 (18)	11(10)	96 (45)	46 (45)
Diarrhea	16 (12)	8 (10)	7 (7)	4 (9)	168 (12)	102 (11)	43 (30)	51 (33)	5 (3)	7 (6)	18 (8)	12 (12)
Vomiting	12 (9)	6 (8)	9 (9)	8 (17)	173 (12)	134 (14)	21 (15)	24 (16)	7 (5)	1 (<1)	36 (17)	14 (14)
General disorders and administration site conditions												
Chills	6 (5)	2 (3)	10 (10)	3 (7)	33 (2)	32 (3)	5 (3)	14 (9)	8 (5)	4 (4)	12 (6)	1 (<1)
Influenza like illness	1 (1)	NR	9 (9)	6 (13)	23 (2)	10 (1)	3 (2)	1 (<1)	4 (3)	1 (<1)	1(<1)	NR
Injection site reaction	14 (11)	16 (20)	1 (1)	NR	42 (3)	31 (3)	14 (10)	13 (9)	NR	1 (<1)	39 (18)	19 (18)
Pyrexia	4 (3)	4 (5)	9 (9)	6 (13)	189 (13)	130 (14)	61 (42)	52 (34)	7 (5)	3 (3)	37 (17)	27 (26)
Peripheral edema	9 (7)	10 (13)	NR	NR	72 (5)	34 (4)	7 (5)	5 (3)	2 (1)	2 (2)	14 (7)	4 (4)
Metabolism and nutrition disorders												
Hyperkalemia	3 (2)	3 (4)	10 (10)	2 (4)	2 (<1)	2 (<1)	NR	NR	NR	NR	NR	1 (<1)
Musculoskeletal and connective tissue disorders												
Arthralgia	16 (12)	6 (8)	23 (24)	3 (7)	45 (3)	43 (5)	5 (3)	11 (7)	3 (2)	3 (3)	5 (2)	3 (3)
Bone pain	1 (<1)	NR	6 (6)	1 (2)	47 (3)	26 (3)	3 (2)	NR	NR	1 (<1)	1(<1)	NR
Myalgia	3 (2)	1 (1)	6 (6)	NR	46 (3)	25 (3)	8 (6)	9 (6)	2 (1)	3 (3)	2 (<1)	NR
Pain in extremity	7 (5)	7 (9)	15 (15)	2 (4)	37 (3)	19 (2)	10 (7)	13 (8)	6 (4)	2 (2)	7 (3)	4 (4)
Nervous system disorders												
Convulsion	1 (<1)	2 (3)	2 (2)	NR	12 (<1)	4 (<1)	2 (1)	2 (1)	NR	NR	NR	NR
Headache	22 (17)	14 (18)	33 (34)	20 (43)	98 (7)	50 (5)	28 (19)	32 (21)	17 (12)	16 (14)	25 (12)	9 (9)
Respiratory, thoracic and mediastinal disorders												
Cough	5 (4)	1 (1)	9 (9)	8 (17)	98 (7)	66 (7)	37 (26)	22 (14)	2 (1)	2 (2)	10 (5)	NR
Resp tract congestion	NR	NR	9 (9)	2 (4)	NR	NR	1 (<1)	NR	NR	NR	NR	NR

System/Organ Class	<u>CRF</u>		<u>Oncology</u>		<u>HIV</u>		<u>ABD</u>		<u>Surgery</u>			
	<u>Predialysis</u>		<u>Dialysis</u>		EPO	Non-ESA	EPO	Placebo	EPO	Non-ESA	EPO	Placebo
	EPO	Placebo	EPO	Placebo								
Adverse Drug Reaction	N=131	N=79	N=97	N=46	N=1404	N=930	N=144	N=153	N=147	N=112	N=213	N=103
	n (%)	n (%)	n (%)	n (%)	n (%)	n (%)	n (%)	n (%)	n (%)	n (%)	n (%)	n (%)
Skin and subcutaneous tissue disorders												
Rash ^a	8 (6)	6(8)	11(11)	2(4)	93 (7)	47 (5)	36 (25)	19 (12)	3 (2)	2 (2)	8 (4)	2 (2)
Vascular disorders												
Embolism and thrombosis ^b	2 (2)	NR	15 (15)	2 (4)	76 (5)	33 (4)	7 (5)	1 (<1)	6 (4)	3 (3)	18 (8)	6 (6)
Deep vein thrombosis	NR	NR	NR	NR	24 (2)	6 (<1)	NR	NR	2 (1)	2 (2)	10 (5)	3 (3)
Thrombosis	NR	NR	4(4)	1 (2)	18 (1)	6 (<1)	NR	NR	2 (1)	NR	3(1)	NR
Hypertension ^c	35 (27)	20 (25)	32 (33)	5 (11)	43 (3)	24 (3)	3(2)	4 (3)	NR	2 (2)	23 (11)	9 (9)

ADB=autologous blood donation; NR=not reported;

^a Rash includes urticaria and angioedema

^b Includes arterial and venous, fatal and non-fatal events, such as deep venous thrombosis, pulmonary emboli, retinal thrombosis, arterial thrombosis (including myocardial infarction), cerebrovascular accidents (i.e. stroke including cerebral infarction and cerebral haemorrhage), transient ischaemic attacks, and shunt thrombosis (including dialysis equipment) and thrombosis within arteriovenous shunt aneurisms

^c Hypertension includes hypertensive crisis and hypertensive encephalopathy

Post-marketing experience

Adverse drug reactions identified during the postmarketing experience with epoetin alfa are included in **Table 2**. In the table, the frequencies are provided according to the following convention:

Very common	≥1/10
Common	≥1/100 and < 1/10
Uncommon	≥1/1,000 and <1/100
Rare	≥1/10,000, <1/1,000
Very rare	<1/10,000, including isolated reports

Antibody-mediated pure red cell aplasia has been very rarely reported (<1/10,000 cases per patient-year) after months to years of treatment with EPREX.

Table 2. Adverse Drug Reactions Identified During Post-marketing Experience with EPREX by Frequency Category Estimated from Spontaneous Reporting Rates

System/Organ Class	
<i>Frequency</i>	<i>Adverse Drug Reaction</i>
Blood & Lymphatic System Disorders	
<i>Very rare</i>	Erythropoietin Antibody-Mediated Pure Red Cell Aplasia Thrombocythaemia

Reporting of suspected adverse reactions:

Reporting suspected adverse reactions after authorisation of the medicine is important. It allows continued monitoring of the benefit/risk balance of the medicine. Healthcare professionals are asked to report any suspected adverse reactions <https://pophealth.my.site.com/camreportnz/s/> .

4.9 Overdose

Response to EPREX is dose-related and individualised. In case of excessive erythropoietic response from an overdose of EPREX, dosing should be stopped and phlebotomy can be considered. Supportive care should be provided for hypertensive or convulsive events that may be related to overdosing with epoetin alfa (rch).

For advice on the management of overdose please contact the National Poisons Centre on 0800 POISON (0800 764766).

5. PHARMACOLOGICAL PROPERTIES

5.1 Pharmacodynamic properties

Pharmacotherapeutic group: anti-anaemic, ATC code: B03XA01.

Mechanism of action

Erythropoietin (EPO) is a glycoprotein hormone produced primarily by the kidney in response to hypoxia and is the key regulator of red blood cell (RBC) production. EPO is involved in all phases of erythroid development, and has its principal effect at the level of erythroid precursors. After EPO binds to its cell surface receptor, it activates signal transduction pathways that interfere with apoptosis and stimulates erythroid cell proliferation. Recombinant human EPO (Epoetin alfa), expressed in Chinese hamster ovary cells (rch), has a 165 amino acid sequence identical to that of human urinary EPO; the two are indistinguishable on the basis of functional assays. The apparent molecular weight of erythropoietin is 32,000 to 40,000 daltons.

5.2 Pharmacokinetic properties

Erythropoietin stimulates erythropoiesis in anaemic patients with chronic renal failure in whom the endogenous production of erythropoietin is impaired. Because of the length of time required for erythropoiesis – several days for erythroid progenitors to mature and be released into the circulation – a clinically significant increase in haemoglobin is usually not observed in less than two weeks and may require up to ten weeks in some patients.

Measurement of epoetin alfa (rch) following intravenous administration showed 10% excretion by the kidneys with the major routes of elimination not determined. After intravenous administration the mean half lives in normal volunteers ranged from 4.0 to 6.1 hours and in patients with chronic renal failure from 6.5 to 9.3 hours. Following subcutaneous injection, serum levels are much lower than the levels achieved following IV injection; the levels increase slowly and reach a peak between 12 and 18 hours post-dose. The peak is always well below the peak achieved using the IV route (approximately 1/20th of the value). Following subcutaneous injection, erythropoietin serum levels remain elevated above baseline for about 72 hours. There is no accumulation when thrice weekly dosing is used: the levels remain the same, whether they are determined 24 hours after the first injection or 24 hours after the last injection. The half-life is difficult to evaluate for the subcutaneous route and is estimated about 24 hours. The bioavailability of subcutaneous injectable erythropoietin is much lower than that of the intravenous drug: approximately 20-30%. No information is available in the young and in the elderly. Due to decreased metabolism patients with hepatic dysfunction may have increased erythropoiesis with EPREX.

ESAs are growth factors that primarily stimulate red cell production. Erythropoietin receptors may be expressed on the surface of a variety of tumour cells.

5.3 Preclinical safety data

Carcinogenesis, mutagenesis

Long-term carcinogenicity studies have not been carried out. There are conflicting reports in the literature regarding whether erythropoietins may play a role as tumour proliferators. These reports, based on *in vitro* findings from human tumour samples, are of uncertain significance in the clinical situation. In a standard series of assays for genotoxic potential, Epoetin alfa (rch) did not induce gene mutations or cause chromosomal damage.

6. PHARMACEUTICAL PARTICULARS

6.1 List of excipients

Sodium chloride

Monobasic sodium phosphate dihydrate

Dibasic sodium phosphate dihydrate

Sodium citrate*

Glycine

Polysorbate 80

Water for injection

* *buffer in epoetin alfa bulk drug substance*

6.2 Incompatibilities

In the absence of compatibility studies, this medicine must not be mixed with other medicines.

6.3 Shelf Life

EPREX 1,000 IU/ 0.5 mL solution for injection in pre-filled syringe – 18 months.
EPREX 2,000 IU/ 0.5 mL solution for injection in pre-filled syringe – 18 months.
EPREX 3,000 IU/ 0.3 mL solution for injection in pre-filled syringe – 24 months.
EPREX 4,000 IU/ 0.4 mL solution for injection in pre-filled syringe – 24 months.
EPREX 5,000 IU/ 0.5 mL solution for injection in pre-filled syringe – 24 months.
EPREX 6,000 IU/ 0.6 mL solution for injection in pre-filled syringe – 24 months.
EPREX 8,000 IU/ 0.8 mL solution for injection in pre-filled syringe – 24 months.
EPREX 10,000 IU/ 1.0 mL solution for injection in pre-filled syringe – 18 months.
EPREX 20,000 IU/0.5 mL solution for injection in pre-filled syringe – 18 months
EPREX 30,000 IU/0.75 mL solution for injection in pre-filled syringe – 18 months
EPREX 40,000 IU/ 1.0 mL solution for injection in pre-filled syringe – 18 months.

6.4 Special precautions for storage

Store at 2°C to 8°C. This temperature range should be closely maintained until administration to the patient. Do not freeze or shake.

Store in original package in order to protect from light.

When the product is about to be used, it may be removed from the refrigerator and stored at room temperature (below 25°C) for a maximum single period of seven days.

6.5 Nature and contents of container

Pre-filled syringe (type I glass) with plunger (Teflon-faced rubber) and needle with a needle shield (rubber with polypropylene cover) and a PROTECS™ needle guard device (polycarbonate) attached to the syringe.

The needle cover contains dry natural rubber (a derivative of latex). See **section 4.4**.

1,000 IU/0.5mL; 2,000 IU/0.5mL; 3,000 IU/0.3mL; 4,000 IU/0.4mL; 5,000 IU/0.5mL; 6,000 IU/0.6mL; 8,000 IU/0.8mL; 20,000 IU/0.5mL, 30,000IU/0.75mL and 10,000 IU/1.0mL: in boxes of 6 pre-filled syringes.

40,000 IU/1.0mL in boxes of 1 pre-filled syringe.

Not all strengths and/or pack sizes may be marketed.

6.6 Special precautions for disposal and other handling

The product should not be used, and discarded

- if the seal is broken,
- if the liquid is coloured or you can see particles floating in it,
- if you know, or think that it may have been accidentally frozen, or
- if there has been a refrigeration failure.

Any waste material should be disposed of in accordance with local requirements.

The product is for single use only.

The pre-filled syringes are fitted with the PROTECS™ needle guard device to help prevent needle stick injuries after use. The EPREX Consumer Medicine Information includes full instructions for the use and handling of pre-filled syringes. See **section 4.2**.

7. MEDICINE SCHEDULE

Prescription Medicine.

8. SPONSOR

Janssen-Cilag (New Zealand) Ltd

Auckland, NEW ZEALAND

Telephone: 0800 800 806

Fax: (09) 588 1398

Email: medinfo@janau.jnj.com

9. DATE OF FIRST APPROVAL

13 October 1997 (1,000 IU/0.5mL; 2,000 IU/0.5mL; 3,000 IU/0.3mL; 4,000 IU/0.4mL; 5,000 IU/0.5mL; 6,000 IU/0.6mL; 8000 IU/0.8mL; 10,000 IU/1.0mL) and 6 May 1999 (20,000 IU/0.5mL, 40,000 IU/1mL) and 12 Feb 2009 (30,000IU/0.75mL).

10. DATE OF REVISION OF THE TEXT

20 December 2024

Summary table of changes

Section	Summary of new information
4.4	Addition of new Precaution on Abuse potential.